



# The next level of needle detectability: shifting the paradigm

## Introduction

Vaccines and proper vaccine administration are an integral part of modern swine production. In the U.S., assuming a high herd health status, it has been estimated that roughly 120 million market hog injections occur annually.<sup>1</sup> Twenty years ago, Neogen® introduced Ideal D3® detectable needles into the swine industry to help prevent broken needles from entering the food chain. Since then, the use of detectable needles has become a staple of The National Pork Board's PQA Plus® program.<sup>2</sup> Ideal D3® needles are a thick-walled cannula to help prevent breakage. More importantly, the cannula is comprised of a highly ferritic metallurgy, that was designed to be detectable in the processing plant at line speed through magnetic resonance detection. At the farm level, if a broken needle occurs in a pig, standard operating procedures call for that pig to be tagged, marked, and/or euthanized. However, there are occasions where the speed of the vaccinator, combined with the scarcity of labor, complicated by the movement of unrestrained pigs in a pen can result in the unintended consequence of a broken needle cannula found in the carcass of a pig either in the processing plant or even worse, on the dinner plate of a consumer. Therefore, Neogen reimagined the Ideal D3® needle to add an extra layer of visual detection in conjunction with a feature for the practical removal at the farm level, all while maintaining its proven reliability of detection in processing plants.

## Materials and Methods

Finite Element Analysis (F.E.A) simulation was conducted on standard 304SS cannula as well as Neogen 2205SS cannula to evaluate the strength in response to applied force at various points along the length of the needle to determine baseline data for the most probable break point. This was replicated on 14G, 16G, 18G, and 20G needles that varied in length from ½ inch to 1.5 inches. Each needle was analyzed under the same loading and boundary or support conditions to maintain uniformity within the study. All force and pressure placements utilized the tip of the needle as the reference point to establish consistency throughout the analysis. SolidWorks and SolidWorks Simulation<sup>3</sup> were the tools utilized to complete this analysis (Figure 1). A highly visible extraction collar was designed to be added to the cannula at a specific distance beyond the maximum stress point as determined by F.E.A simulation. This would allow for the needle cannula to break at the weakest point while the secured extraction collar would remain intact on the cannula (Figure 2). The polypropylene extraction collar was designed as a highly visible practical retrieval feature as well as an observable early warning indicator to alert vaccination personnel to a weakened or compromised needle.

## Results and Discussion

F.E.A. simulation confirms that the weakest point of the needle remains at the cannula hub juncture. The repetitive stress and pressure which a needle encounters during usage has the ability to compromise its strength and result in either bending or breakage at this identified location on the cannula. The addition of the highly visible extraction collar at a specified distance beyond the maximum stress point did not shift the break point and allows for an observable early warning indicator to alert personnel to compromised cannula integrity thereby providing the vaccination personnel the opportunity to change the needle prior to failure. If needle breakage does occur, the extraction collar is designed to stay intact on the separated component that is in contact with the animal from disappearing into the subcutaneous or deeper tissue. Further, the highly visible extraction collar flares and provides a practical means for personnel to simply retrieve, by hand, the separated component of the needle cannula from the pig without any additional equipment required (Figure 3).





Therefore, confirming removal eliminates the need to tag out or euthanize the animal. In the design of the needle, it was necessary to add length to the cannula with the addition of the extraction collar to maintain the designated injection length. The highly ferritic 2205SS cannula is still up to 100% detectable in processing plants at line speed with magnetic resonance systems for an added layer of food security. This patent pending needle by Neogen is referred to as the D3X™ needle (Figure 4).

*References:*

- 1 The National Pork Board 2018 Pork Industry Needle Forum Report
- 2 The National Pork Board PQA Plus® Education Handbook (2019 release)
- 3 SolidWorks and SolidWorks Simulation by Dassault Systemes

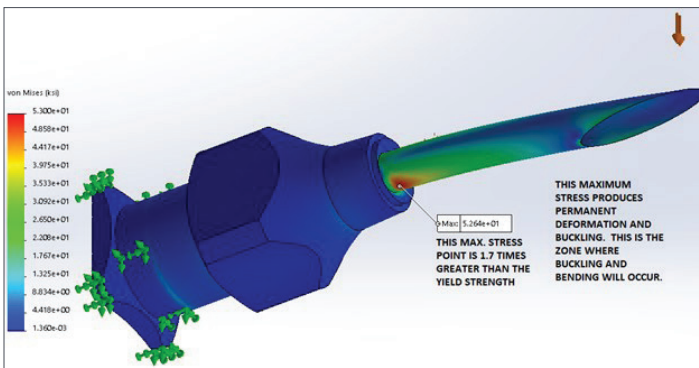

Figure 1: F.E.A Simulation on standard needle

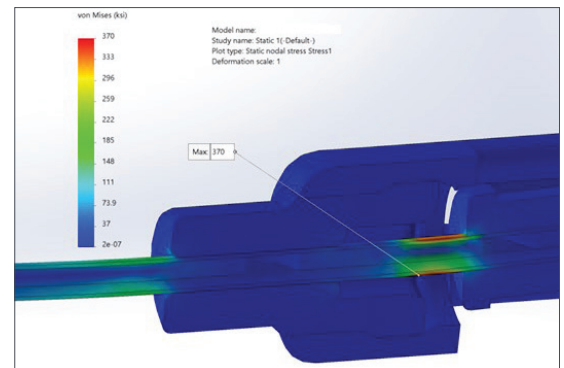

Figure 2: F.E.A. Simulation on needle with extraction collar



Figure 3: Highly visible extraction collar in pig



Figure 4: D3X needle assembly



Figure 5: D3X Needles logo

